

POSITIONER

H. Tracy Hall

12 JAN 1966

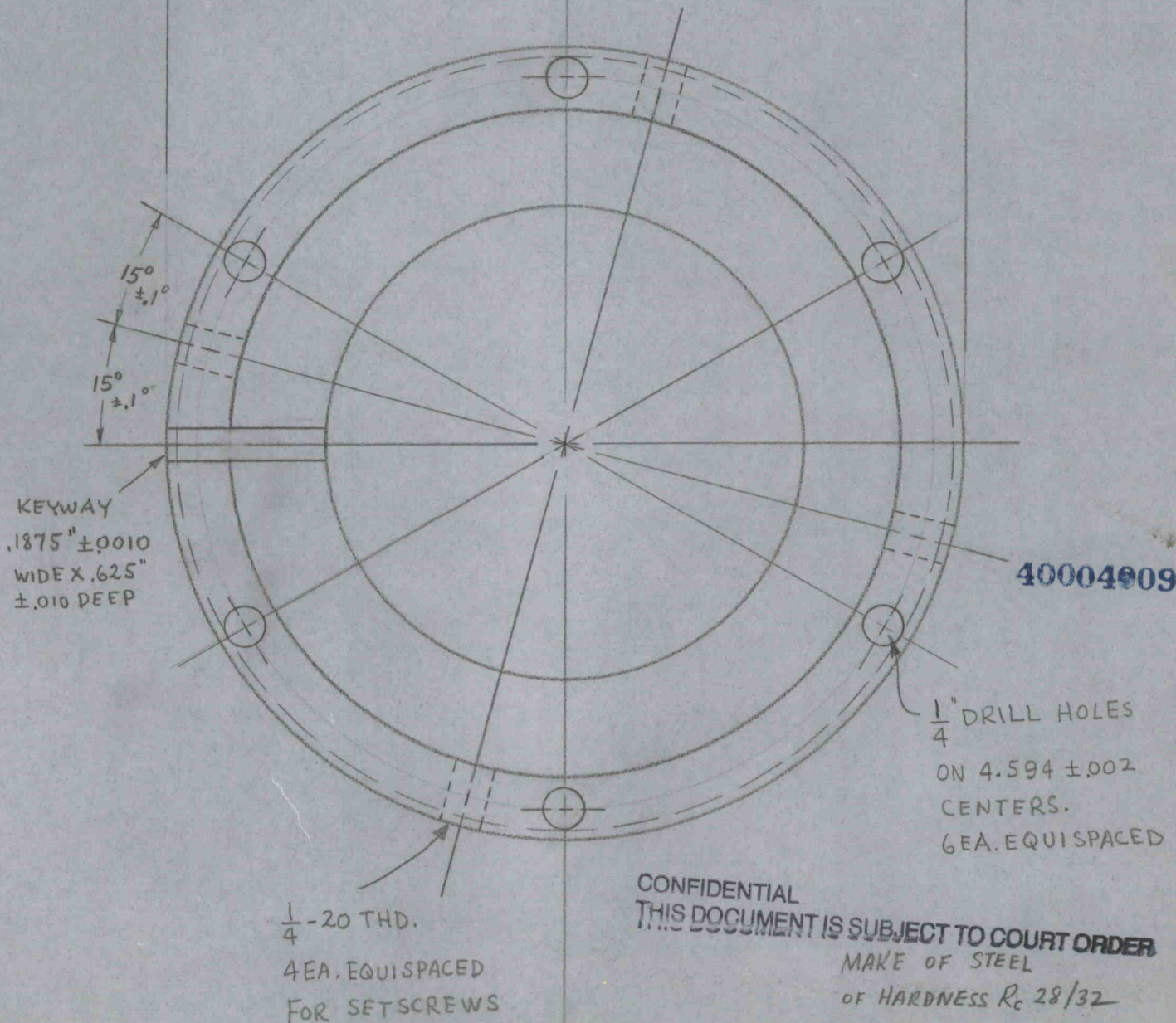
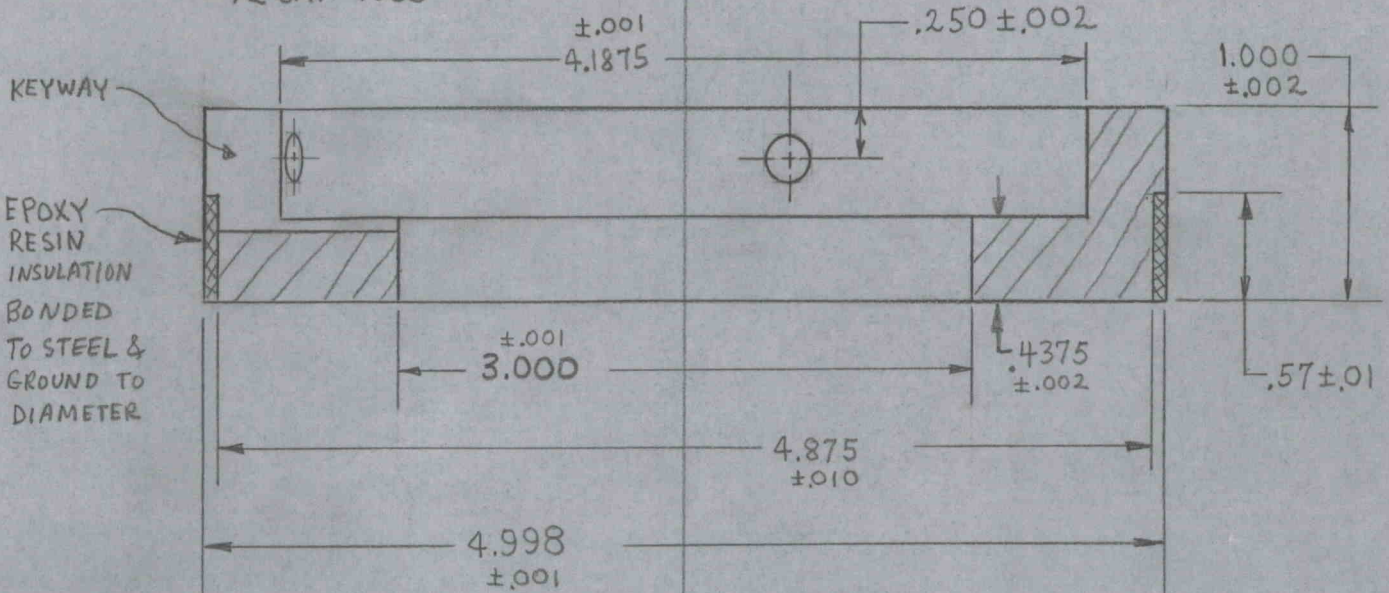

GUIDE PLATE

H. J. Hall
12 Jan 1966

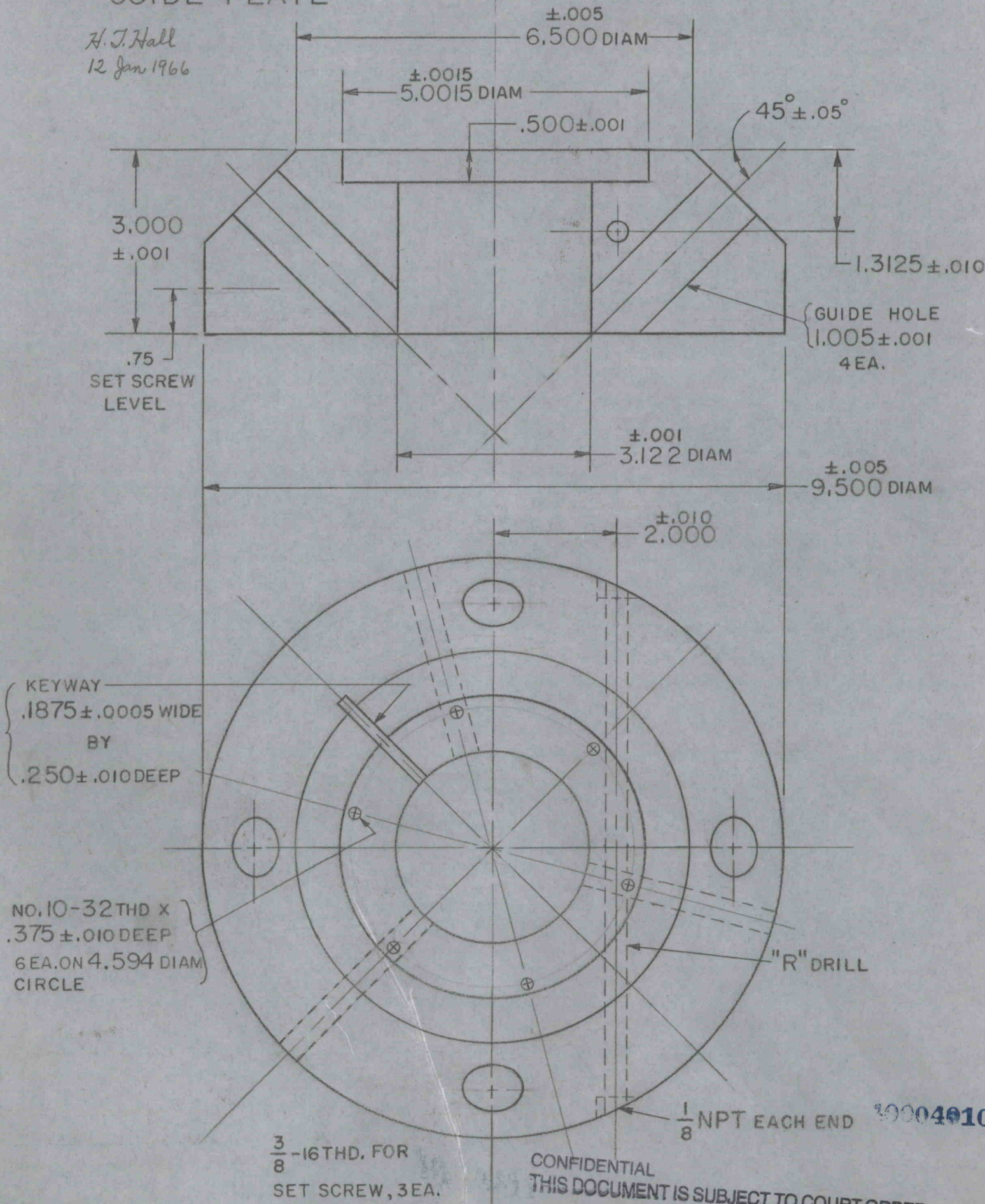

CONFIDENTIAL
THIS DOCUMENT IS SUBJECT TO COURT ORDER
MAKE OF HARD ALUMINUM
WITH MINIMUM YIELD > 50,000 PSI

10004010

FINISHED PIECE
IS 5.500 ±.001 THICK

±.005
16.500 D

11.000 D
±.005

13.700 D
±.002

1.005 D
±.001

90°
±.05°

RAM BASE

45°
±.05°

5.500 ±.001 THICK

3.625
±.005

±.005
1.250

±.005
2.500

±.005
1.625 1/8" R

2.749
±.001

±.005
2.250

4.515
±.002

RAM BASE, 200 TON CUBIC P.
HARDNESS R_c 28/32
MAKE OF 4340 STEEL FORGING
AIRCRAFT QUALITY, MAGNAFLUXED

40004911

6EA. REQ'D.

H. Tracy Hall 13 JAN 1966

CONFIDENTIAL
THIS DOCUMENT IS SUBJECT TO COURT ORDER